



EPSILON PALFINGER

EPSILON UNLIMITED



plus

English

Power
+ Speed
+ Precision

= EPSILON for more applications than you imagine



Content

page



E65L, E75L

4
5



E90L, E110L, E125L

6
7



E140L, E160L

8
9



E190LS, E250L, E260L

10
11



E65Z, E75Z

12
13



E90Z, E110Z, E120Z

14
15



E140Z, E165Z

16
17



E250Z

18



Equipment

19
28



Grabs

29



Accessories

29



E380L

30

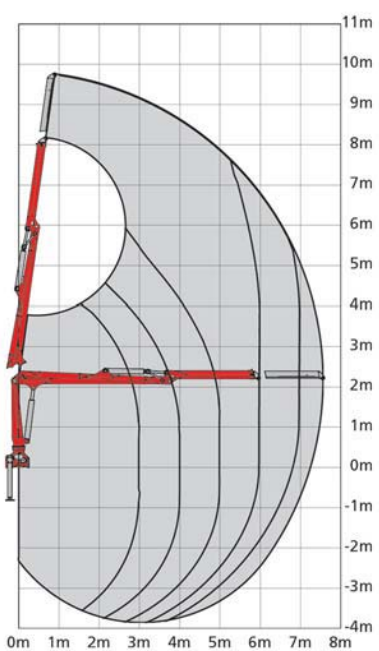

E65L76 / E75L76

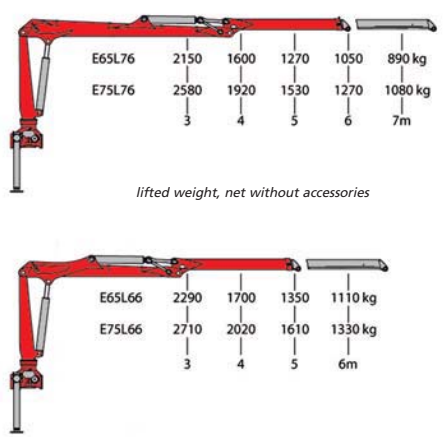

crane type	E65L		E75L		
	66	76	66	76	
boom system					
lifting moment net	[kNm]		66	65	
slewing torque net	[kNm]		14	16	
slewing angle	[°]		425	425	
max. outreach	[m]		6,6	7,6	
operating pressure	[bar]		195	220	
max. pump capacity	[l/min]		2x60	2x60	
dead weight	[kg]	1340	1370	1390	1420

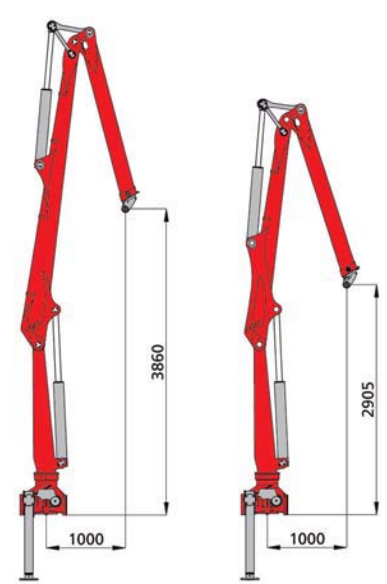

76

66

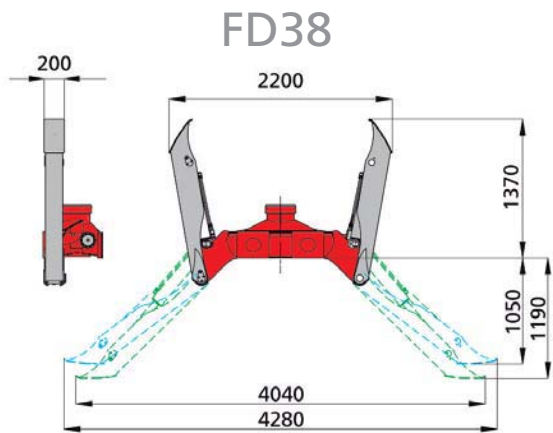
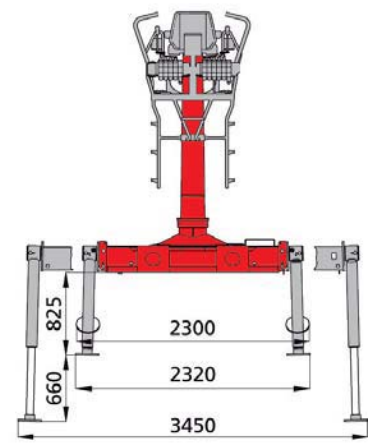
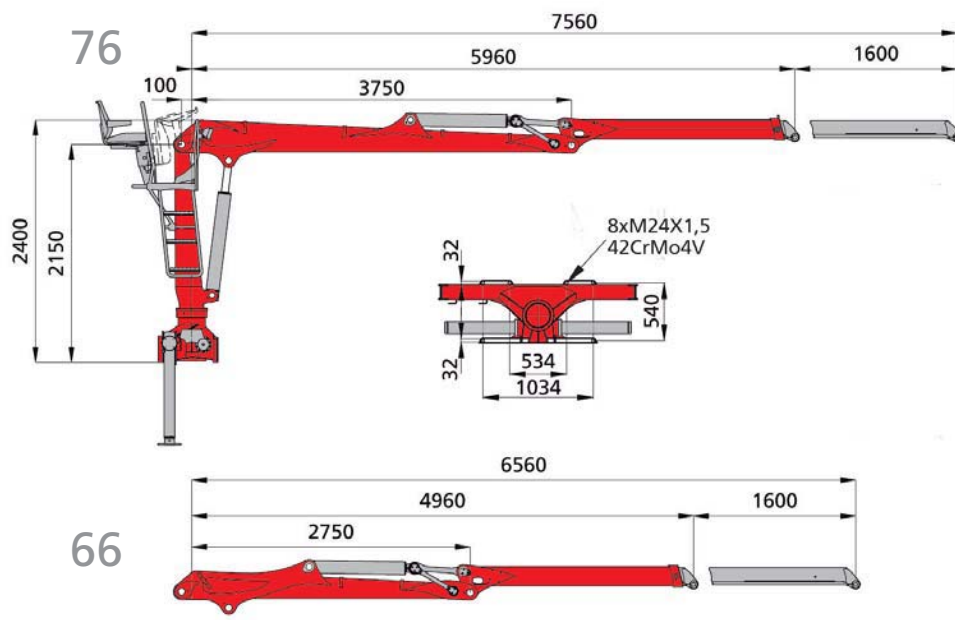

VA
short stabilizer legs

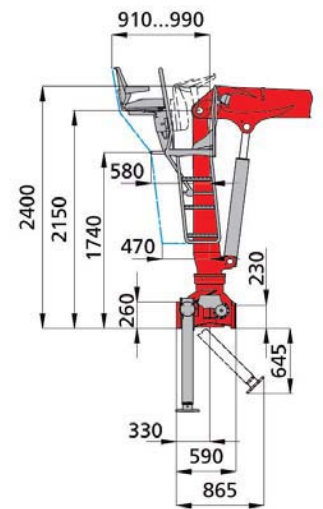
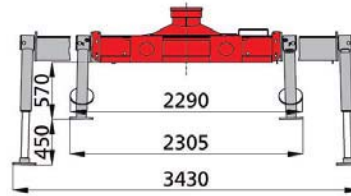
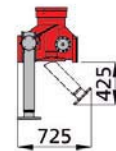

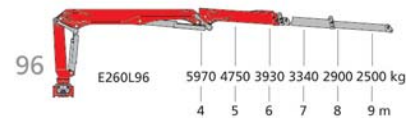
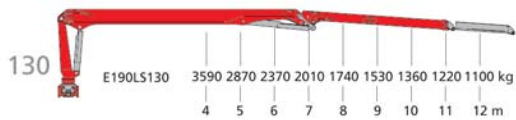
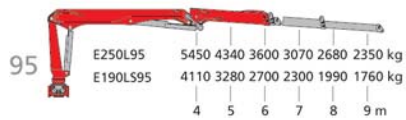
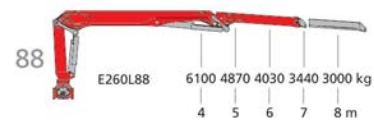
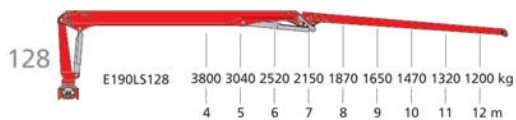
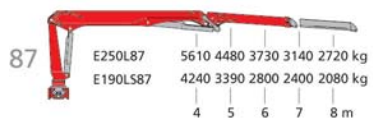
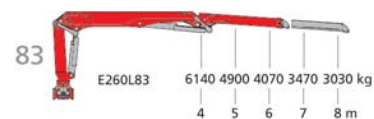
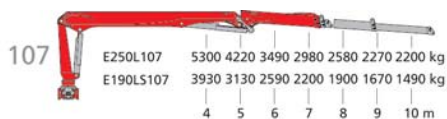
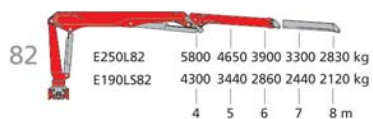

lifted weight, net without accessories

crane type	E190LS						E250L				E260L		
boom system	82	87	95	107	128	130	82	87	95	107	83	88	96
lifting moment net [kNm]	181	177	165	157	152	144	241	230	221	213	251	241	231
slewing torque net [kNm]	33						36				39		
slewing angle [°]	395						395				395		
max. outreach [m]	8,2	8,7	9,5	10,7	12,8	13,0	8,2	8,7	9,5	10,7	8,3	8,8	9,6
operating pressure [bar]	215						270				260		
max. pump capacity [l/min]	2x90						2x90				2x90		
dead weight [kg]	2050	2140	2300	2460	2380	2510	2050	2140	2300	2460	2200	2290	2450
dead weight SRX47 [kg]							450						
dead weight FD250 [kg]							550						

E190LS / E250L
E260L

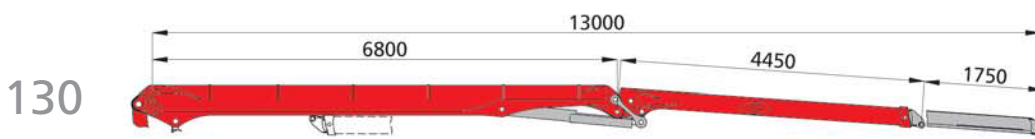
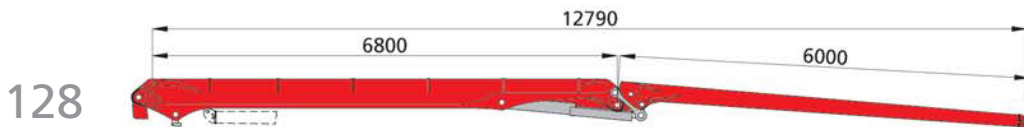
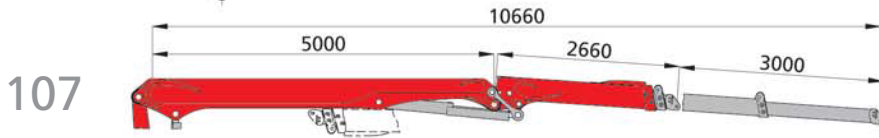
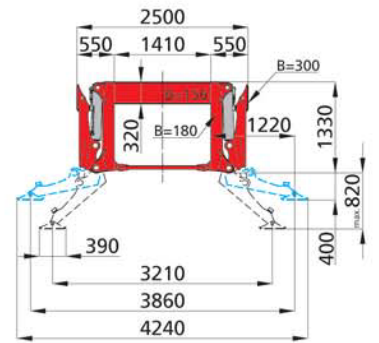
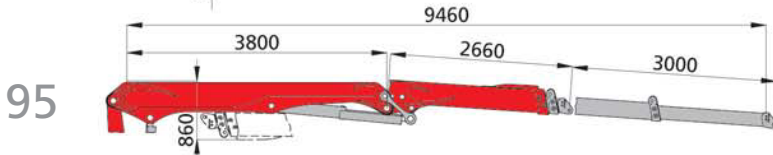
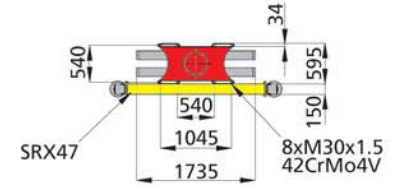
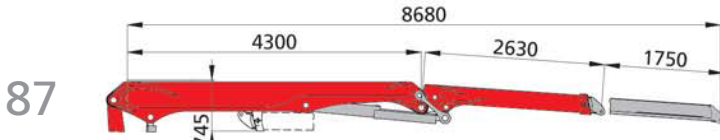
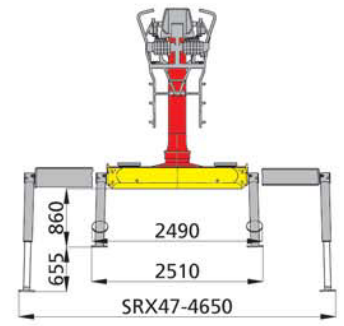
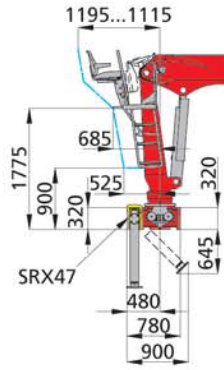
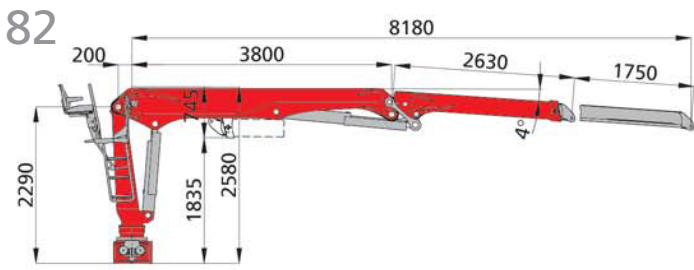

FD250

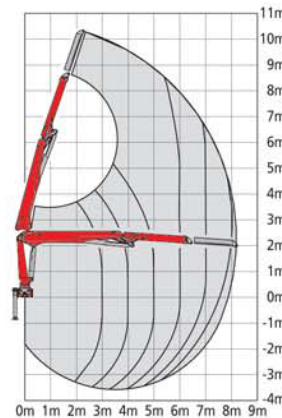
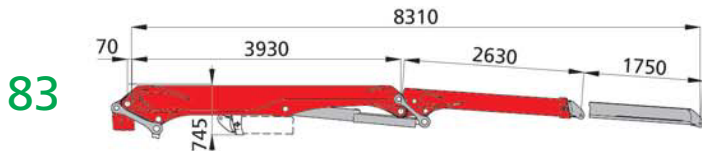

E190LS82 / E250L82

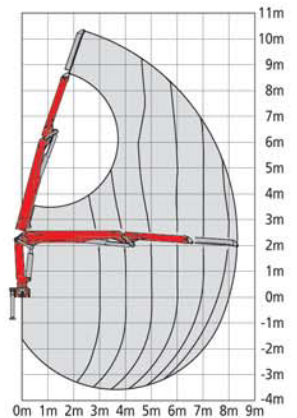
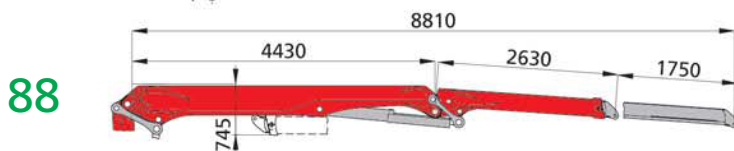

E260L83

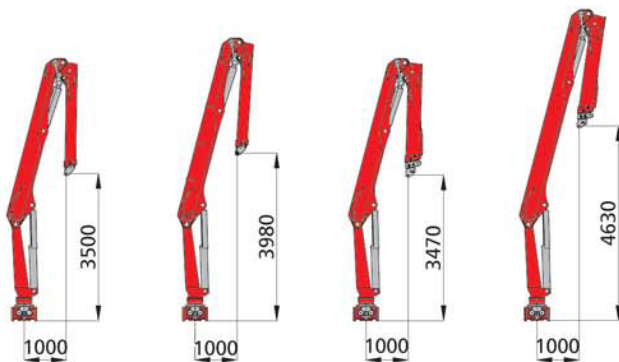
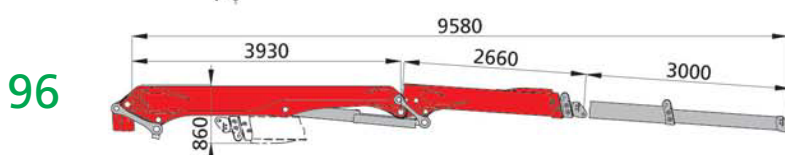

82 87 95 107

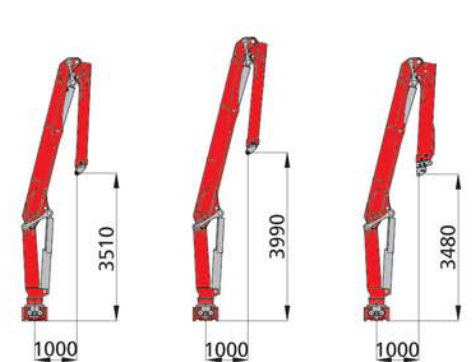

83 88 96

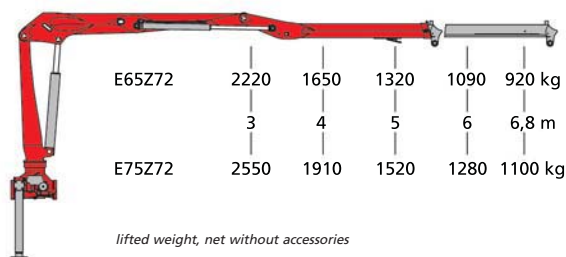
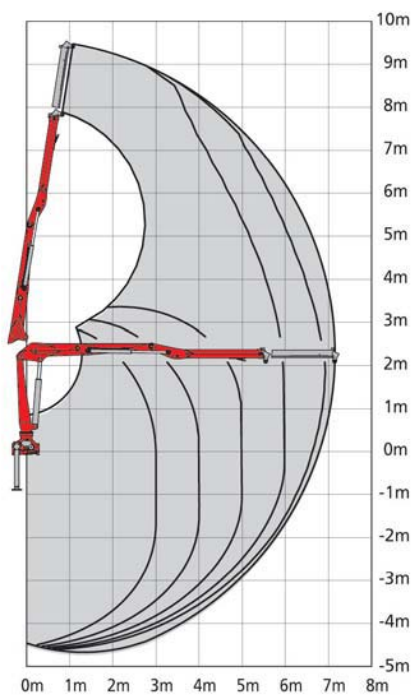

crane type		E65Z	E75Z
lifting moment net	[kNm]	65	75
slewing torque net	[kNm]	14	16
slewing angle	[°]	425	425
max. outreach	[m]	7,2	7,2
operating pressure	[bar]	195	220
max. pump capacity	[l/min]	2x60	2x60
dead weight	[kg]	1390	1440



E65Z72 / E75Z72